

SMDC Controller

Mobile Lubrication Systems

Operation

The SMDC Controller is a multi-purpose programmable controller used with on-board mobile lubrication systems. The unit is energized by the vehicle or machine's ignition switch. Controller settings are saved whenever power is interrupted. Up to four operating modes can be selected which allows the controller to be used with various lubrication system designs. A voltage selector switch is located inside the enclosure for both 12 and 24 VDC service.

Features

- + Digital status display on front cover for easy programming
- + System monitoring capabilities
- + Data memory function initiated at power down
- + Compact design

Technical Data

Operating Voltage	12 VDC, 24 VDC (factory setting)	
IP Enclosure Rating	External terminal strip	IP-47
	Liquid tight connector	IP-67
Fault Relay Contacts	24 VDC, 1 amp	
Ambient Temperature	-4°F to 104°F (-20°C to 40°C)	
Weight	0.3 kg	
Electrical Fuse	10 amp	

Installation

Mount the controller in a clean area with easy access for programming and visual checking. Mount controller on a flat surface.

How to Order

Name	Description	Part #
SMDC Controller	Controller with external terminal strip	33346ME
	Controller with liquid tight connector	33346E

When ordering, specify by name, description and part number, e.g. SMDC Controller with external terminal strip, Part #33346ME.

Accessories

Description	Part #
Replacement Fuse	31076-5



Controller Status LEDs

Red Steady	Lubrication cycle
Yellow Steady	Low Level
Green Steady	Power supply on
None Lit	No input power to controller

NOTE:

+ Part number will be labeled with Rev #“R3”

BIJUR DELIMON INTERNATIONAL

(919) 465 4448 LOCAL
 (800) 631 0168 TOLL-FREE
 (919) 465 0516 FAX

WWW.BIJURDELIMON.COM

2250 Perimeter Park Dr., Suite 120
 Morrisville, NC 27560

Electrical Terminal Connections

Motor Driven Lubricators

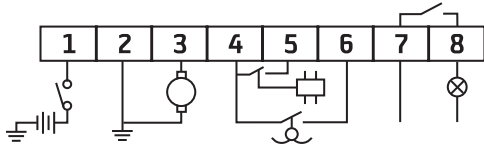

Pneumatically-activated Lubricators

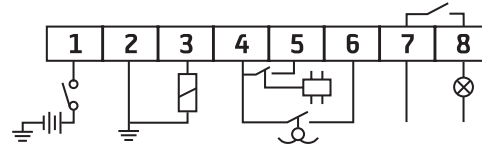

Connection #	Description
1	Positive (+) 12 or 24 VDC supply
2	Negative (-) chassis ground
3	Motor output 12 or 24 VDC
4	Common (for cycle completion and low level inputs)
5	Input- cycle completion Mode 2 (pressure switch) Mode 3 (cycle switch)
6	Input- low level (closed at low level)
7 & 8	Fault switch (normally open contact rating 1 amp max)

Operation

Voltage Selection

Before connecting with the power supply, set the voltage switch on the top-left of main circuit board to the correct position for desired input voltage (12 or 24 VDC).

Keys Description



Select



Enter and reset



Step selection



Adjustment

With the controller energized:

- + Press keys **S** and **R** simultaneously and release to enter control mode.
- + The display panel will now show a fixed letter for the selected mode and a flashing number (1-4).
- + To select the required mode press the **▲** key.
- + Press the **S** key to advance to the next parameter of the selected mode.
- + Repeat steps 3 and 4 above using the **◀▶** key to move across the digits and the **▲** key to change the value of the selected flashing digit.
- + On completion, press the **R** key to save the data and initiate a lubrication cycle.

Manual Override

- + With the controller energized press the **R** key to initiate a lubrication cycle.

Program Review

- + To review the preset data, press the **S** key repeatedly with the controller energized.
- + To return to operating condition display, press **R** key or release **S** key for 5 seconds.

Fault Alarm

- + In any alarm condition, e.g. low level, low pressure etc., the pump will not be able to operate and the alarm will be displayed. For low level, the level LED will illuminate. The fault condition must be rectified to cancel the alarm and reactivate the system.

Legend



Chassis ground



Power supply
(12 or 24 VDC)



DC motor



DC solenoid



Cycle switch or
pressure switch



Low level switch
(closed at low level)



Alarm light (Typ.)

Wiring an NPN Cycle Switch

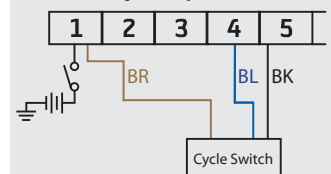

Operation Mode

Timer Control Mode (d 1)

Recommended for Systems without a Pressure Switch or Cycle Switch

Low level alarm function enabled*

In this mode, the lubricating system runs according to the preset run time and idle time.

Pressure Control Mode (d 2)

Recommended for Injector Systems

**Pressure switch function enabled/
Low level alarm function enabled***

A pressure switch installed downstream from the pump

functions as the key monitoring device for the entire system. Normally the system will build up sufficient pressure required to activate the pressure switch (normally open) in a predetermined period of time (called monitor time) once the pump starts. The user can adjust the monitor time to a setting greater than the time required to satisfy the pressure switch (normally 1.5 times greater). If the system fails to reach sufficient pressure during that time period an alarm signal will be displayed (EEPP appears on the digital readout). Possible causes for this type of alarm could be pump malfunction, broken supply line or crushed supply line prior to pressure switch. Lubrication intervals are adjustable from 1 to 9999 (seconds/minutes/hours). An adjustable run delay (1-99 seconds) following a pressure switch closure assures adequate pressure downstream from the pump.

Cycle Control Mode (d 3)

Recommended for Progressive systems

Cycle switch function enabled/ Low level alarm function enabled*

The cycle switch mounted on a progressive divider valve is the key monitoring device for the entire system. Normally when grease is being discharged from the outlets of the divider valve, a cycle pin engages with the switch, confirming a successful lubrication cycle. The controller can be programmed to allow for a predetermined number of cycle counts (1-999). Once the preset number of counts is obtained the controller will stop the pump and revert back to the idle time setting (1-9999 seconds/minutes/hours). If there is no activity from the cycle switch within a specified period of time (Monitor time: 1-999 seconds), an alarm signal will be displayed (EEcY appears on the digital readout). Possible causes for this type of alarm could be pump malfunction, divider valve malfunction, broken supply line or blocked supply line or feed line.

Pulse Control Mode (d 4)

Recommended for Pulse systems

Low level alarm function enabled*

This mode is designed for pulse systems where the pump doesn't run continuously, such as a pneumatically actuated piston pump. The controller can be programmed to initiate multiple on/off signals to a solenoid valve for frequent cycling of the pump.

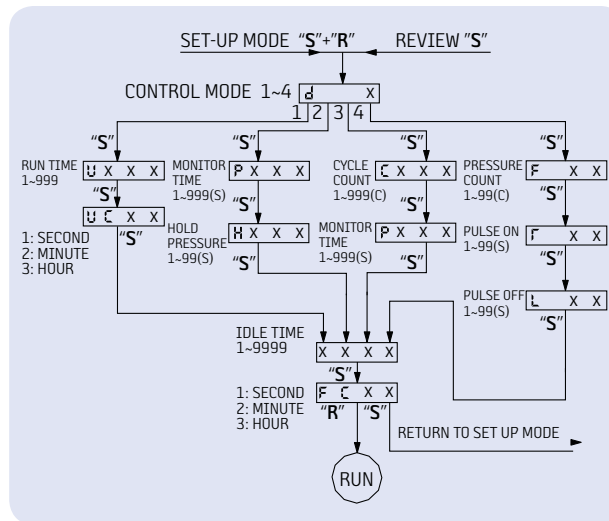

* For lubricators fitted with low level switch

Operation Mode Cont.

Advanced Setup Mode

In Advanced Setup Mode, additional features may be set to suit special application requirements.

To enter Advance Setup Mode:

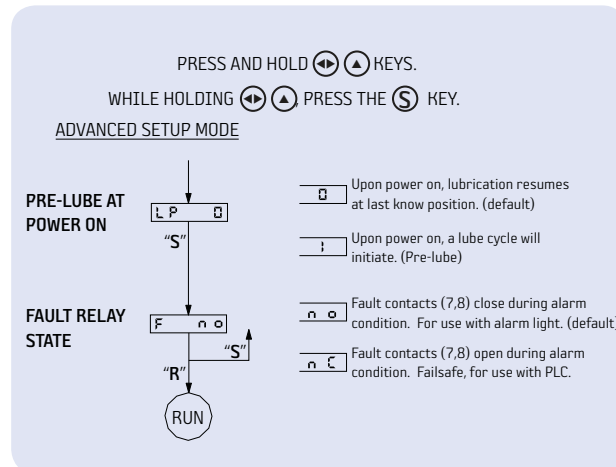

Fault Conditions:

- **"EEPP"-Monitor time-out**
(Mode d2 - Injectors) Pressure switch did not activate within monitor time.
- **"EEHP"-Pressure switch failure**
(Mode d2 - Injectors) Pressure switch was activate at the beginning of a lube cycle. Once customer fixes pressure switch - alarm will clear automatically.
- **"EEcY"-Monitor time-out**
(Mode d3 - Progressive) Cycle switch did not activate within monitor time.
- **"EE"-Internal memory failure**
(Checked at power up) No recovery. Turn off power and try again. If problem persists, replace control.
- **"EELL"-Yellow LED -Low Level**
(Steady Yellow) Low lubricant level has been detected.
- **"LLPP"-Green LED -Low Voltage**
Check and apply correct voltage

BIJUR DELIMON INTERNATIONAL

(919) 465 4448 LOCAL
(800) 631 0168 TOLL-FREE
(919) 465 0516 FAX

WWW.BIJURDELIMON.COM

2250 Perimeter Park Dr., Suite 120
Morrisville, NC 27560

Dimensional Schematics

Measurements shown in millimeters.

EXTERNAL TERMINAL STRIP

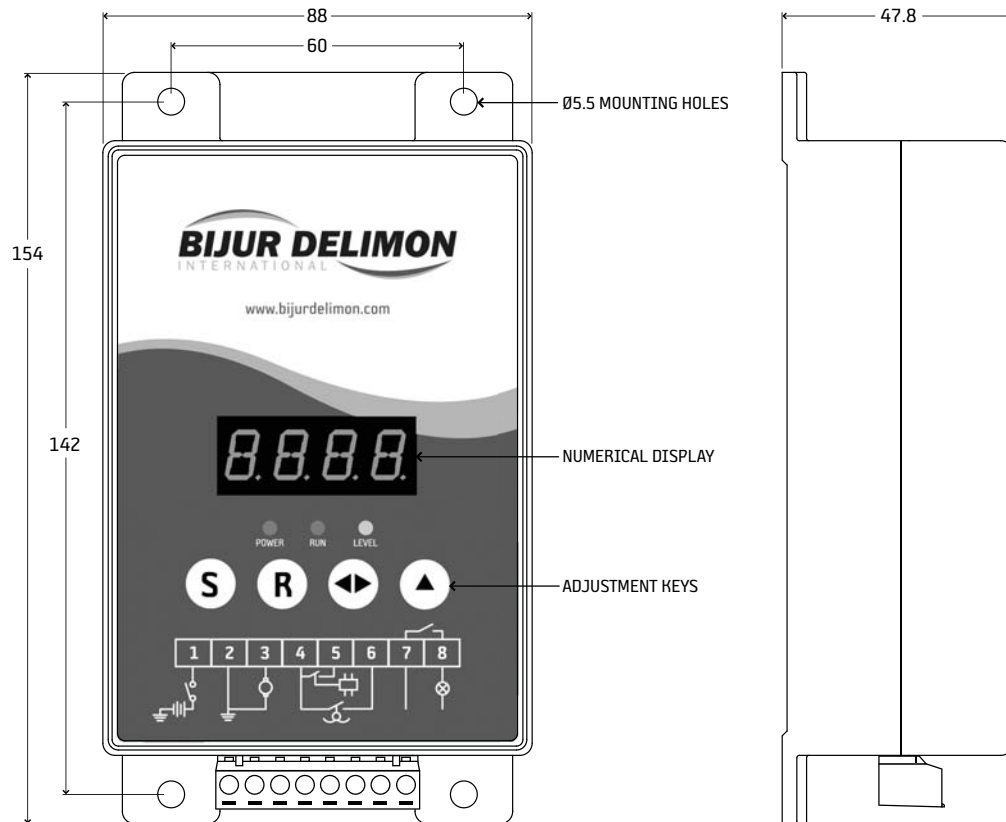

LIQUID TIGHT CONNECTOR

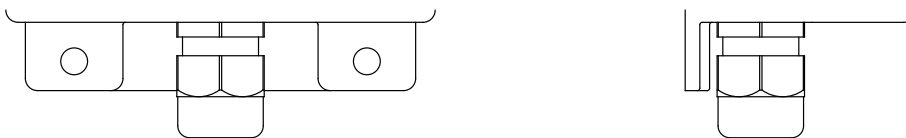

BIJUR DELIMON INTERNATIONAL

(919) 465 4448 LOCAL
(800) 631 0168 TOLL-FREE
(919) 465 0516 FAX

WWW.BIJURDELIMON.COM

2250 Perimeter Park Dr., Suite 120
Morrisville, NC 27560