

INDEX

	Page
1. General	2
2. Safety	2 – 4
A. Distributor type	4
B. Number of segments	4
C. Inspection	5
D. Monitoring	5
E. Coding of the outlets	5
F. Accessories	5
3. Application	5
4. Design and Function	5
5. Specification	6
6. Explanation	7
7. Plates	7



1. General

Prior to start up, we recommend to read these operating instructions carefully as we do not assume any liability for damages and operating troubles which result from the nonobservance of these operating instructions!

Any use beyond the applications described in these operating instructions is considered to be not in accordance with the product's intended purposes. The manufacturer is not to be held responsible for any damages resulting from this: the user alone bears the corresponding risk.

As to figures and indications in these operating instructions we reserve the right to make technical changes which might become necessary for improvements.

The copyright on these operating instructions is kept reserved to the company DELIMON. These operating instructions are intended for the erecting, the operating and supervising personnel. They contain regulations and drawings of technical nature which must not – completely or partially - be distributed nor used nor communicated to others without authorization for competition purposes.

Company address, spare parts and service address

DELIMON

Arminstraße 15

D-40277 Düsseldorf

Phone : +49 211 77 74-0

Fax : +49 211 77 74-210

Branch office

Am Bockwald 4

D-08344 Grünhain-Beierfeld

E-mail : kontakt@bijurdelimon.com

www.bijurdelimon.com

2. Safety

These operating instructions contain fundamental instructions which are to be observed during erection, operation and maintenance. Therefore it is absolutely necessary for the fitter and the competent qualified staff/user to read these operating instructions before installation and start-up. The operating instructions must be available at all times at the place of use of the machine/system.

Not only the general safety instructions stated under this main point "safety" are to be observed, but also the other specific safety instructions stated under the other main points.

2.1 Identification of safety warnings in the operating instructions

The safety warnings contained in these operating instructions which, if not observed, may cause dangers to people, are specially marked with general danger symbols



safety sign according to DIN 4844, warning about a danger spot ,

in case of warning about electric voltage with



safety sign according to DIN 4844, warning about dangerous electric voltage.

In case of safety instructions which, if not observed, may cause damage to the machine and its function, the word

ATTENTION

is inserted.

Instructions that are directly attached to the machine, as for example

- rotational direction arrow
- identifications for fluid connections

must be observed at all events and maintained in a fully legible condition.

- Note: There is an increased skid risk in case of spilled/leaked out lubricants. They are to be removed at once properly.



Safety sign according to DIN 4844, warning about skid risk.

2. Safety (continuation)

2.2 Personnel qualification and training

The operating, maintaining, inspecting and erecting personnel must have the appropriate qualification for such work. Area of responsibility, competence and supervision of the personnel have to be regulated by the user. If the personnel do not have the necessary knowledge, they have to be trained and given instructions. This can be effected, if necessary, by the manufacturer/supplier on behalf of the user of the machine. Furthermore, the user has to make sure that the contents of the operating instructions are fully understood by the personnel.

2.3 Dangers in case of nonobservance of the safety instructions

The nonobservance of the safety instructions may result in hazards to persons, to the environment and to the machine. The nonobservance of the safety instructions may lead to the loss of any claims for damages.

In detail, the nonobservance may for instance lead to the following hazards:

- Failure of important functions of the machine/system
- Failure of prescribed methods for maintenance and repair
- Hazard to persons by electrical, mechanical and chemical influences
- Hazard to the environment by the leakage of dangerous substances

2.4 Safety conscious working

The safety instructions stated in these operating instructions, the existing national regulations as to the accident prevention as well as possible internal working, operating and safety rules of the user are to be observed.

2.5 Safety instructions for the user/operator

- If hot or cold machine parts lead to dangers, these parts have to be protected against touch.
- Protection against touch for moving parts (e. g. coupling) must not be removed when the machine is in operation.
- Leakages (e. g. from the shaft seal) of hazardous goods to be delivered (e. g. explosive, toxic, hot) are to be removed in such a way that there is no danger to persons and environment. Legal rules are to be observed.
- Hazards caused by electrical power are to be excluded (for details please refer for instance to the rules of the VDE and the local power supply companies).

2.6 Safety instructions for maintenance, inspection and installation work

The user has to take care that all the maintenance, inspection and installation work is executed by authorized and qualified skilled personnel who have informed themselves adequately by thoroughly studying the operating instructions.

Basically, work on the machine is only to be carried out during shut-down. It is obligatory to observe the shut-down procedure described in the operating instructions.

Pumps or pump aggregates that deliver media being hazardous to health have to be decontaminated. Immediately after completion of the work, all safety and protective equipments have to be reinstalled and/or reactivated.

- Advice: When working with compressed air, do wear glasses.



(DIN 4844 – Use breathing mask)

- Advice: Observe EC-Safety Data Sheet for materials of consumption and additives used and use personal protective equipment.



(DIN 4844 – Use breathing mask)

Before recommissioning, observe the points stated in section “initial start-up”.

2.7 Unauthorized conversion and manufacture of spare parts

Conversion or modifications to the machine are only permitted when agreed with the manufacturer. Original spare parts and accessories authorized by the manufacturer serve to ensure safety. The use of other parts may render the liability for consequential losses null and void.

2. Safety (continuation)

2.8 Unacceptable modes of operation

The operational reliability of the machine supplied is only guaranteed if the machine is used in accordance with its intended purposes as per section 1 - General - of the operating instructions. The limiting values specified in the data sheet must on no account be exceeded.

2.9 Guidelines & standards

1., 2. and 3. guideline (see data sheet: R&N_2009_1_GB)

3.0 Notes on environmental protection and waste disposal

In correct operation with lubricants, the components are subject to the special requirements set by environmental legislation.

The general requirements for lubricants are specified in the respective safety data sheets.

Used lubricants are hazardous forms of waste and therefore require special supervision in the sense of § 41 paragraph 1 sentence 1 and paragraph 3 no. 1 of KrW-/AbfG (Closed-Loop Waste Management Act).

Used oils must be handled in compliance with AltölV (Waste Oil Ordinance).

The devices or components contaminated with lubricant must be disposed of by a certified waste management company.

Records of proper waste management must be filed in conformance to NachwV (Ordinance on Waste Recovery and Disposal Records).

GENERAL PRODUCT CHARACTERISTICS

- Progressive distributor
- up to 24 outlets
- Electronic monitoring possible
- Metered volume: variable from 0.5 cm³
- Lubricant: grease, fluid grease, oil

A. DISTRIBUTOR TYPE ZPB

B. NUMBER OF SEGMENTS

- 3 segment
- 4 segment
- 5 segment
- 6 segment
- 7 segment
- 8 segment
- 9 segment
- 10 segment
- 11 segment
- 12 segment

C. INSPECTION

Stage A

D. MONITORING

with non-return valve, with motion indicator
with non-return valve, with monitoring switch

E. CODING OF THE OUTLETS

A segment
M segment
E or M segment

F. ACCESSORIES

without
Slot angle
Overpressure indicator 70 or 100 bar

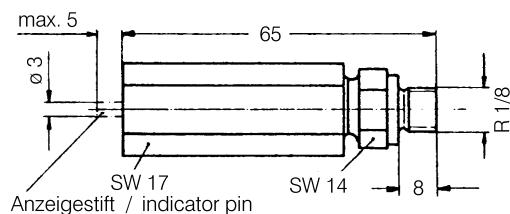

3. Application

The major element of a progressive system is the lubricant distributor.

Distributors ZP-B are used to divide and meter lubricant in total loss central lubrication systems (oil, liquid grease and grease) and in oil recirculation systems suitable for small, medium and large machine plants

4. Design and Function

ZP-B distributors consist of several individual segments (at least 3 in the standard version) that are screwed together and sealed against each other. Depending on the arrangement within the distributor, the following segment types are available:

- Initial- or A-segment
- Medium or M-segment
- Final- or E-segment

The distributor ZP-B has the task to divide the lubricant volume (oil or grease) received under pressure into portions and to deliver them successively to the up to 24 possible outlets. This is achieved due to pistons which are moved by the lubricant being under pressure, and forcibly controlled by each other. The pistons move into their final positions, and the lubricant waiting in front of the piston is successively supplied to the lubrication points.

The distributor works as long as it is supplied with lubricant.

On request, the distributor is equipped with integrated nonreturn valves. These nonreturn valves, which are integrated in the distributor outlets, have the advantage that the distributor works reliably even in case of small lubricant volumes and higher counterpressures involved as far as the line material is flexible.

In case that a visual operational monitoring of the distributor is necessary or desired, the distributor has to be ordered with motion indicators. For the extended version with motion indicators, it is possible to provide additionally an electrical operational monitoring by means of an electronical monitoring switch.

5. Specification

Working pressure max. : 300 bar
 Temperature range: – 20 °C to + 80 °C (higher temperatures on request)
 Admissible differential pressure between 2 outlets: max. 50 bar
 with non-return valves max. up to admissible system pressure
 Metered volume per piston stroke: at choice 0.5; 1.2 or 2.0 cm³
 Flow volume for oil and grease: min. 0.5 cm³/min; max. 1500, 3000, 5000 cm³/min*
 Opening pressure of nonreturn valves: 2 bar
 Response pressure: < 10 bar
 Usable lubricants on mineral oil basis:
 Lubricating greases up to NLGI class 3 DIN 51818
 Oil ISO VG 68 to 1500 (DIN 51519) at 20 °C ambient temperature
 Synthetic lubricants on request
 Pipe connections:
 Inlet Ø 10
 Outlet Ø 6, Ø 8 or Ø 10

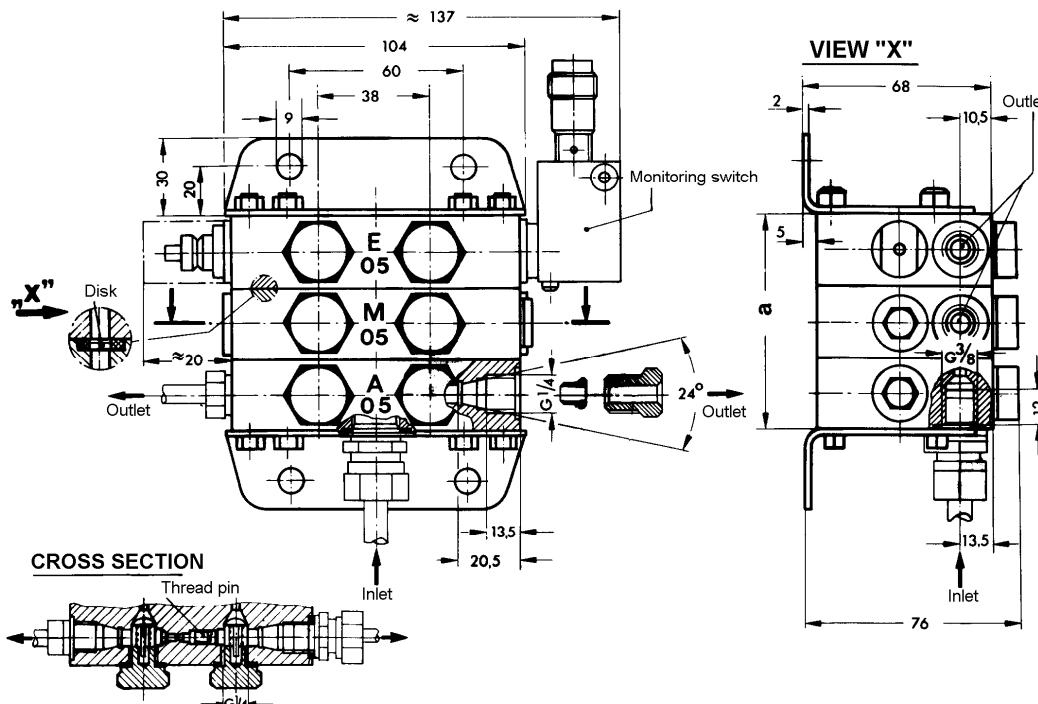

* choose always smallest flow rate as basis in case of distributors having different flow volumens.

max. Number of outlets	Number of segments	Dimension (mm) a	Weight approx. kg
6	3	75	3.07
8	4	100	4.85
10	5	125	6.07
12	6	150	7.28
14	7	175	8.48
16	8	200	9.70
18	9	225	10.92
20	10	250	12.13
22	11	275	13.34
24	12	300	14.56

ATTENTION

Special care has to be taken that the quantity of lubricant metered by a piston does not escape in the same segment but in the adjacent segment next to the inlet port. The metered volume of the piston in the initial segment is discharged at the final segment.

6. EXPLANATION

- The basic design of distributor ZP-B is illustrated by a symbol; the channel bores drawn into the symbol show that the metered volume of one segment is principally carried to the adjacent segment located next to the "inlet" port - with one exception: the metered volume of the initial segment is carried back to the final segment. Each segment of the distributor is marked with the respective metered volume.

05 is equal to 0.5 cm³ per piston stroke
 12 is equal to 1.2 cm³ per piston stroke
 20 is equal to 2.0 cm³ per piston stroke

- There are various possibilities of combining several metered volumes and delivering them to a single outlet port. The following 3 letter symbols are available to mark these possibilities and the arrangement of the outlets.

Symbol "a" shows the position of the outlet port.

Symbol 'b' to denote longitudinal cross-porting of both volumes within one element, remove thereto the thread pin in the respective element. This combination is feasible in the initial segment only by means of an external separate bridge.

The bridge is available as special accessories (item No. : 634212311).

Symbol "c" denotes the combination of the metered volumes of neighbouring segments; for this, the disks between the segments in direction of the inlet port are removed. This combination is not feasible in the initial segment.

- Metering volume at outlet port (cm³)

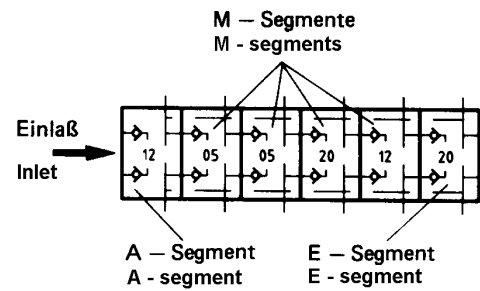

↓ a | b — c

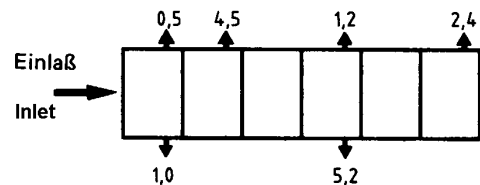
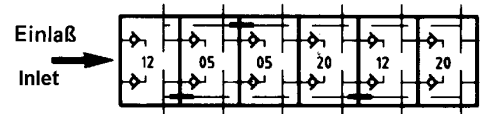
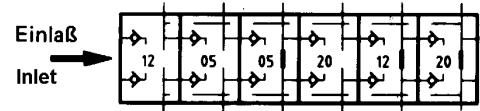
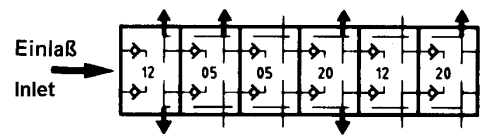

7. Plates

Type plate 26 x 52mm (75511-1311)

