

Operating Instructions
Modular valve
SDM

INDEX

	Page
1. General	2
2. Safety	3 – 5
A. Divider type	5
B. Metered volume	5
C. Revision	5
D. Metering	6
E. Accessories	6
3. Operation	6
4. Installation	7
5. Adjustment	7
6. Parts List	7



1. General

Prior to start up, we recommend to read these operating instructions carefully as we do not assume any liability for damages and operating troubles which result from the nonobservance of these operating instructions!

The below described divider is designed for use in centralized lubrication systems to distribute the supplied lubricant. Any use beyond the applications described in these operating instructions is considered to be not in accordance with the product's intended purposes. The manufacturer is not to be held responsible for any damages resulting from this: the user alone bears the corresponding risk.

As to figures and indications in these operating instructions we reserve the right to make technical changes which might become necessary for improvements.

The copyright on these operating instructions is kept reserved to the company BIJUR DELIMON International. These operating instructions are intended for the erecting, the operating and supervising personnel. They contain regulations and drawings of technical nature which must not – completely or partially - be distributed nor used nor communicated to others without authorization for competition purposes.

Company address, spare parts and service address

DELIMON-Denco Lubrication
DELIMON-Cooling
United Kingdom
Ramsden Court, Ramsden Road
Rotherwas Industrial Estate
Hereford
HR2 6LR

Phone: +44 (0) 1432 365 000
Fax: +44 (0) 1432 365 001
info@delimon.co.uk
www.bijurdelimon.com

DELIMON GmbH
Arminstraße 15
D-40277 Düsseldorf
Phone : +49 211 77 74-0
Fax : +49 211 77 74-210

Branch office
Am Bockwald 4
D-08344 Grünhain-Beierfeld
E-mail : kontakt@bijurdelimon.com
www.bijurdelimon.com

2. Safety

These operating instructions contain fundamental instructions which are to be observed during erection, operation and maintenance. Therefore it is absolutely necessary for the fitter and the competent qualified staff/user to read these operating instructions before installation and start-up. The operating instructions must be available at all times at the place of use of the machine/system.

Not only the general safety instructions stated under this main point "safety" are to be observed, but also the other specific safety instructions stated under the other main points.

2.1 Identification of safety warnings in the operating instructions

The safety warnings contained in these operating instructions which, if not observed, may cause dangers to people, are specially marked with general danger symbols



safety sign according to DIN 4844, warning about a danger spot ,
in case of warning about electric voltage with



safety sign according to DIN 4844, warning about dangerous electric voltage.

In case of safety instructions which, if not observed, may cause damage to the machine and its function, the word

ATTENTION

is inserted.

Instructions that are directly attached to the machine, as for example

- rotational direction arrow
- identifications for fluid connections

must be observed at all events and maintained in a fully legible condition.

- Note: There is an increased skid risk in case of spilled/leaked out lubricants. They are to be removed at once properly.



Safety sign according to DIN 4844, warning about skid risk.

2. Safety (continuation)

2.2 Personnel qualification and training

The operating, maintaining, inspecting and erecting personnel must have the appropriate qualification for such work. Area of responsibility, competence and supervision of the personnel have to be regulated by the user. If the personnel do not have the necessary knowledge, they have to be trained and given instructions. This can be effected, if necessary, by the manufacturer/supplier on behalf of the user of the machine. Furthermore, the user has to make sure that the contents of the operating instructions are fully understood by the personnel.

2.3 Dangers in case of nonobservance of the safety instructions

The nonobservance of the safety instructions may result in hazards to persons, to the environment and to the machine. The nonobservance of the safety instructions may lead to the loss of any claims for damages. In detail, the nonobservance may for instance lead to the following hazards:

- Failure of important functions of the machine/system
- Failure of prescribed methods for maintenance and repair
- Hazard to persons by electrical, mechanical and chemical influences
- Hazard to the environment by the leakage of dangerous substances

2.4 Safety conscious working

The safety instructions stated in these operating instructions, the existing national regulations as to the accident prevention as well as possible internal working, operating and safety rules of the user are to be observed.

2.5 Safety instructions for the user/operator

- If hot or cold machine parts lead to dangers, these parts have to be protected against touch.
- Protection against touch for moving parts (e. g. coupling) must not be removed when the machine is in operation.
- Leakages (e. g. from the shaft seal) of hazardous goods to be delivered (e. g. explosive, toxic, hot) are to be removed in such a way that there is no danger to persons and environment. Legal rules are to be observed.
- Hazards caused by electrical power are to be excluded (for details please refer for instance to the rules of the VDE and the local power supply companies).

2.6 Safety instructions for maintenance, inspection and installation work

The user has to take care that all the maintenance, inspection and installation work is executed by authorized and qualified skilled personnel who have informed themselves adequately by thoroughly studying the operating instructions.

Basically, work on the machine is only to be carried out during shut-down. It is obligatory to observe the shut-down procedure described in the operating instructions.

Pumps or pump aggregates that deliver media being hazardous to health have to be decontaminated. Immediately after completion of the work, all safety and protective equipments have to be reinstalled and/or reactivated.

- Advice: When working with compressed air, do wear glasses.



(DIN 4844 – Use breathing mask)

- Advice: Observe EC-Safety Data Sheet for materials of consumption and additives used and use personal protective equipment.



(DIN 4844 – Use breathing mask)

Before recommissioning, observe the points stated in section “initial start-up”.

2. Safety (continuation)

2.7 Unauthorized conversion and manufacture of spare parts

Conversion or modifications to the machine are only permitted when agreed with the manufacturer. Original spare parts and accessories authorized by the manufacturer serve to ensure safety. The use of other parts may render the liability for consequential losses null and void.

2.8 Unacceptable modes of operation

The operational reliability of the machine supplied is only guaranteed if the machine is used in accordance with its intended purposes as per section 1 - General - of the operating instructions. The limiting values specified in the data sheet must on no account be exceeded.

2.9 Guidelines & standards

1., 2. and 3. guideline (see data sheet: R&N_2009_1_GB)

3.0 Notes on environmental protection and waste disposal

In correct operation with lubricants, the components are subject to the special requirements set by environmental legislation.

The general requirements for lubricants are specified in the respective safety data sheets.

Used lubricants are hazardous forms of waste and therefore require special supervision in the sense of § 41 paragraph 1 sentence 1 and paragraph 3 no. 1 of KrW-/AbfG (Closed-Loop Waste Management Act).

Used oils must be handled in compliance with AltölV (Waste Oil Ordinance).

The devices or components contaminated with lubricant must be disposed of by a certified waste management company.

Records of proper waste management must be filed in conformance to NachwV (Ordinance on Waste Recovery and Disposal Records).

GENERAL PRODUCT CHARACTERISTICS

- Dual line
- Adjustable volume
- Motion indicator with cover (two or three window version)
- Modular block
- 1 outlet per module

A. DIVIDER TYPE SDM

B. METERED VOLUME

SDM 1 (0.2 – 2 cm³)

SDM 5 (1 – 10 cm³)

SDM15 (3 – 30 cm³)

C. REVISION

Status A

D. METERING

without

- Motion indicator with cover SDM 1 (3 window version, adjustable dosing)
- Motion indicator with cover SDM 5 (3 window version, adjustable dosing)
- Motion indicator with cover SDM 15 (3 window version, adjustable dosing)
- Motion indicator with cover SDM 1 (2 window version, adjustable dosing)
- Motion indicator with cover SDM 5 (2 window version, adjustable dosing)

E. ACCESSORIES

without

3. Operation

1. With the reversing valve at the pump set to direct the pump flow into the upper supply line, pressurised lubricant pushes the inlet piston down uncovering the internal cross porting hole to the chamber on top of the discharge piston forcing this to move downwards.
2. The pressurised lubricant forces the discharge piston to the end of its stroke and the full measured charge is discharged to the bearing. Further application of pressure in the upper supply line has no effect.
3. When the reversing valve at the pump is changed over, the flow of pressurised lubricant is down directed to the lower supply line. This pushes the inlet piston upwards, uncovering the internal cross porting hole to the chamber beneath the discharge piston forcing this to move upwards.
4. The pressurised lubricant forces the discharge piston to the end of its stroke discharging its measured volume into the same bearing. Further application of pressure in the lower supply line has no effect.

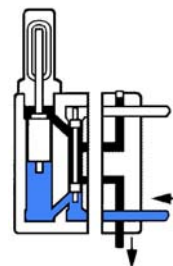
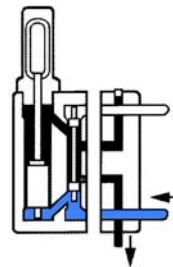
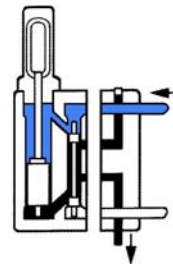
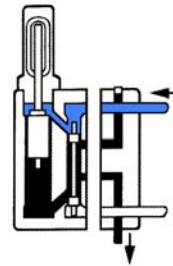

4. Installation

Measuring dividers should be installed in a visible position on the machine as close as possible to the application point. Modular dividers are fitted on piping adaptors onto which can be fitted between one and four modules. Each module can be either double discharge (DDM) or single discharge (SDM) so that a modular measuring divider assembly can feed between one and eight lubrication points by using a combination of both types of module.

The adaptors are first fitted to the machine using the M8 cap screws provided. It is recommended the polythene protective sheeting be retained on the adaptor to prevent ingress of atmospheric contamination. The lubrication system pipework is now complete.

These double modules discharge to two lubrication points per module; one bearing is served on each alternative cycle of the lubrication system.

Finally the operating modules are now fitted to the adaptors using the M4 stainless steel screws provided. The modular divider adaptors have BSPP threads suitable for use with connectors having parallel threads (using a sealing ring) or taper threads where sealing is carried out on the threads.

5. Adjustment

The divider discharge can be adjusted on site after installation to suit the requirement of the lubrication point. The outer flat screw is first removed using a screwdriver. The inner screw can now be re-positioned. Screwing it clockwise (inwards) will restrict the movement of the indicator rod and hence the discharge piston. A smaller volume of lubricant will be delivered each lubrication cycle. Screwing it anti-clockwise will increase the discharge volume. After setting the outer flat screw must be replaced and locked against the inner screw to fix it in position. The bearing/slide should be routinely examined for the presence of lubricant. If excess lubricant is present, the divider discharge volume must be reduced. If the bearing is dry, it must be increased.

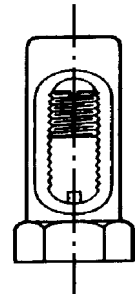

6. PARTS LIST

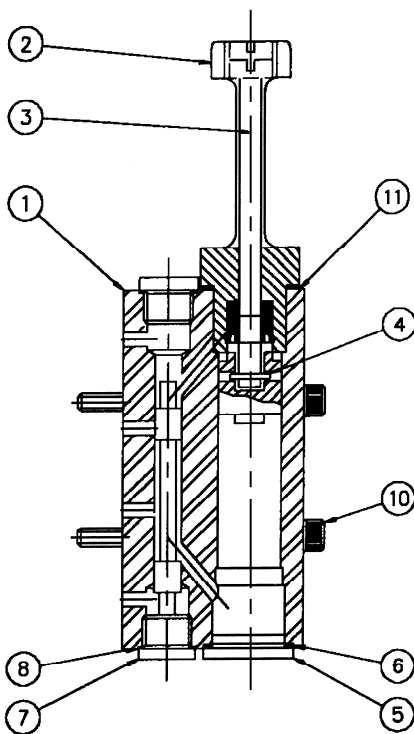

Item	Description	No. Per Module	SDM1	SDM5	SDM15
1	Body/Piston Assembly	1	25566	25584	25594
2	Packing Gland Assembly	1	26053*	26051*	26052*
3	Indicator Stem	1	05960*	05970*	05990*
4	Cross Pin	1	06070*	05390*	05480*
5	Discharge Bore Plug	1	07351	07321	07341
6	Discharge Plug Gasket	1	06670	06690	06340
7	Inlet Bore Plug	2	07291	07351	07351
8	Inlet Plug Gasket	2	06510	06670	06670
9	'O' Ring (not shown)	4	08162	08162	08162
10	Mounting Screw	4	60530	60531	60532
11	Packing Gland Gasket	1	02670*	02700*	02750*

Notes

1. Bodies and divider pistons are not supplied as spares as they are selectively fitted to 10 microns maximum clearance.
2. Packing glands have seals permanently assembled in them.
3. Items marked * are supplied as a packing gland kit to the following part numbers:-

SDM1 - Code No. 18170.
SDM5 - Code No. 18120.
SDM15 - Code No. 18130.