

Product description
Valve & dividers :
Volumetric
injector
FL 32, 33 Grease

DESCRIPTION

FL 30 injectors are perfectly adapted to lubricate all types of machines with a cyclic sequence. Discharge of each injector is adjustable yet delivers a precise amount of lubricant. A visual indicator pin built into each injector makes it easy to confirm a discharge at any lubrication point.

OPERATION

Pressure stage: Pressure from the supply lines moves the injector piston forward. This forces a pre measured amount of lubricant (delivered during the vent stage) out of the discharge chamber outlet. At the same time, lubricant is transferred into the measuring chamber, the indicator stem extends as this chamber fills.

Vent stage: System pressure is vented. The piston retracts to its original position. This movement allows lubricant stored in the measuring chamber to empty into the discharge chamber; the indicator stem retracts.

System outline:

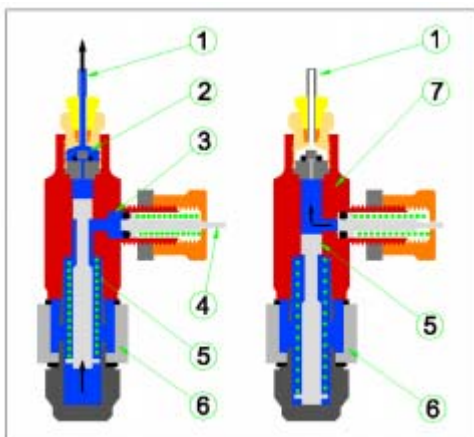

- 1. Lubricant outlet
- 2. Dosing piston
- 3. Pilot piston
- 4. Lubricant inlet
- 5. Idle position
- 6. Discharge cycle
- 7. Release cycle

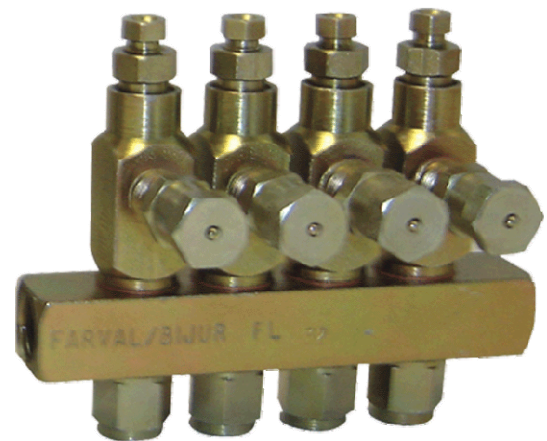

CHARACTERISTICS

Discharge: from 0.016 to 0.131cm³ / cycle FL32
 0.016 to 0.049 cm³ / cycle FL33
 Number of outlets: 1 to 6
 Working pressure: 82 bar mini
 230 bar maxi
 Maximum vent recharge pressure: 14 bar
 Working temperature: 5 to 175° C
 Lubricant to be used: grease NLGI 000 2 max.
 Other lubricants, contact Bijur.
 Materials: galvanised carbon steel and viton seals

HOW TO ORDER

Specify part number in using table below:

Reference injector		Number of outlets
Type FL 32	Type 33	
27163	27164	1*
271631	271641	1
271632	271642	2
271633	271643	3
271634	271644	4
	271645	5
	271646	6
27163R	27164R	#

* Single direct mount FL 32 1 / 4 NPT
 FL 33 1 / 8 NPT

Manifold replacement injector

DRAWING: INJECTOR FL32-33 GREASE

Grease outlet 5/16 - 24 NF for tubing 1/8 "OD".
Adaptor see p3

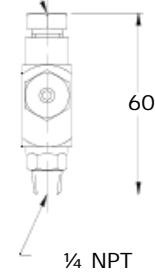

**Injector FL 32
for direct
mounting**

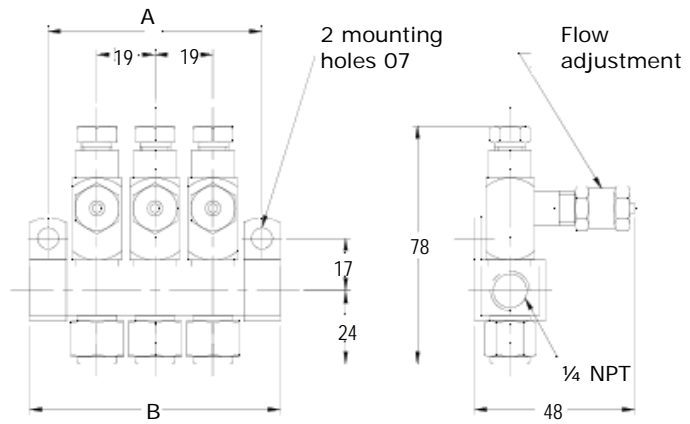

**Injector FL 32
for manifold
mounting**

Grease outlet 5/16 - 24 NF for tubing 1/8 "OD". Adaptor

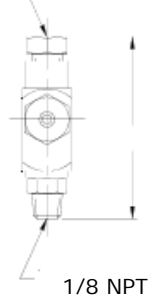

**Injector FL 33
for direct
mounting**

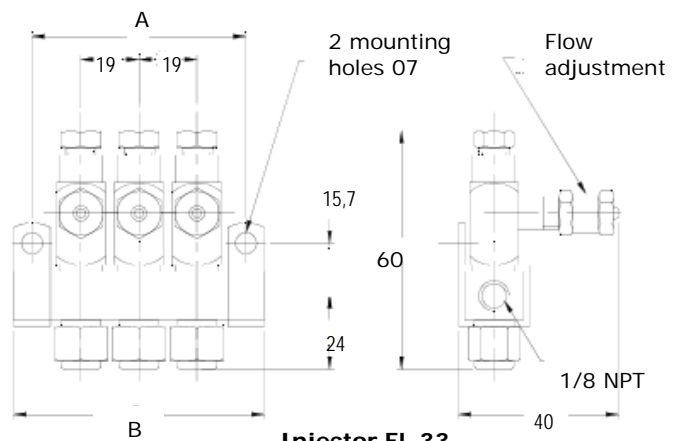

**Injector FL 33
for manifold
mounting**

Number of outlets	Dimensions (mm)			
	Injector FL32		Injector FL33	
	A	B	A	B
1	32	44	30	41
2	51	63	48	60
3	70	82	67	70
4	89	102	87	98
5	-	-	105	117
6	-	-	124	137

Discharge adjustment

On all injectors, the amount of discharge is controlled by the position of the indicator cap.

Fully tighten the indicator cap to obtain the minimum discharge 0,016 Cm3.

To increase the output, loosen the indicator cap as required.

FL 32: 5 turns for the maximum (0.131cc)

FL 33: 2 turns for the maximum (0.049cc)

ACCESSORIES FOR: INJECTOR FL32-33 GREASE

Injector cover caps Part N° 27335

Cover caps in plastic are used in environments where excessive moisture, dirt and other contaminants exist. They are intended to protect the indicator pin to avoid lubricant leakages.

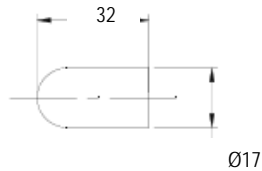

Plug

Can be used to close surplus tapped holes (see table below).

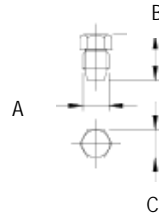

Dimensions (mm)			Reference
A	B	C	
5/16-24NF	13	8	27336
1/8NPT	18	9,5	HP604
1/4NPT	6,4	4,8	HP622

Lock nut Part N° 27347

Nut can be used to replace adjustment screw to obtain a fixed discharge.

Injector FL 32/43: 0,033 cm³ /cycle
 Injector FL 33/42: 0,049 cm³ /cycle

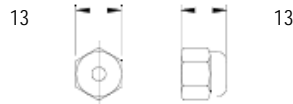

Adapter Part N° 27348

Can be mounted on discharge port.

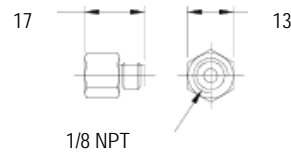

Connector for manual greasing Part N° 27344

Simply a zerk fitting mounted onto a junction. It can be used to fill secondary lines before the first start-up.

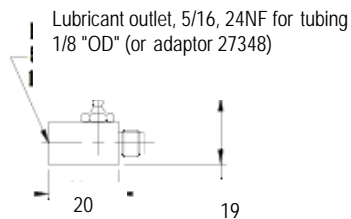

DELIMON

Zentrale

Arminstraße 15
D-40227 Düsseldorf
Telefon: +49 211 7774 0
Telefax: +49 211 7774 210
kontakt@bijurdelimon.com
www.bijurdelimon.com

DELIMON

Niederlassung Beierfeld

Am Bockwald 4
D-08344 Grünhain-Beierfeld

DELIMON

Österreich

Lemböckgasse 49
Haus 2 / Stiege E 4.OG / Top E 4-3
A-1230 Wien
Telefon: +43 1 585 66 17
Telefax: +43 1 585 66 17 50
kontakt@bijurdelimon.com
www.bijurdelimon.com

LUBRIMONSA

Spain

Avda. Txori-Erri 38
48150 Sondica - (Vizcaya)
Teléfono: +34 94 453 20 00
Fax: +34 94 453 25 00
spain@bijurdelimon.com

DENCO Lubrication Ltd.

**DELIMON-Cooling
United Kingdom**

Ramsden Court, Ramsden Road
Rotherwas Industrial Estate
Hereford, HR2 6LR
Phone: +44 (0) 1432 365 000
Fax: +44 (0) 1432 365 001
info@delimon.co.uk
www.bijurdelimon.com

BIJUR Products, Inc.

France

P.O. Box 50
Z.I. de Courtabœuf
9, Avenue du Québec
91942 Courtabœuf Cedex
Tél.: +33 1 692 985 85
Fax: +33 1 690 776 27
contact@bijurdelimon.com
www.bijurdelimon.com

BIJUR Lubricating Ireland Ltd.

Gort Road
Ennis, County Clare
Tel.: +35 3 65 682 1543
Fax: +35 3 65 682 0327
www.bijurdelimon.com

*Für reibungslose Bewegung
For smooth motion*